

ZW-7 series

HITACHI

Reliable solutions

ZW180



WHEEL LOADER

Model code : ZW180-7 / ZW180PL-7

Engine maximum power : 129 kW / 173 hp

Operating weight : 14 950 – 15 710 kg

Bucket ISO heaped : 2.5 – 5.2 m³

You're in control

You're at the heart of Hitachi's design for its latest range of wheel loaders. To continuously improve on previous generation machines, we've focused on enhancing your experience in the cab as an operator.

We've considered the challenges you face as the owner of a successful business. And we've zoomed in on the ways in which we can support you over the life cycle of your machine.

By putting you at the heart of the ZW-7 range, we invite you to take control – over your workspace and your fleet. And by working in partnership, we will help you to create your vision.





Inside



In control of your business

8. Improve your profit



In control of your comfort

10. Feel the difference



In control of your environment

12. Increase your safety



In control of your assets

14. Boost your uptime



In control of your fleet

16. Manage your machine



In control of your uptime

18. Protect your investment



In control of your performance

20. Customise your machine

Complete control

The new ZW-7 range of wheel loaders puts you firmly in control, so you can feel assured of your machine's performance, and supported by the technological expertise and services that Hitachi provides.

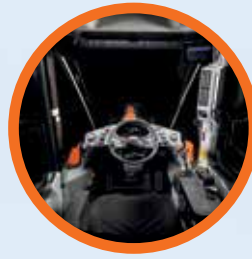

The cab interior provides a comfortable working environment.



Approach speed control maximises fuel efficiency on loading operations.



The payload checker helps you work more productively and accurately when loading trucks.



ConSite Pocket app allows you to manage and monitor your fleet remotely.



Options such as Hitachi ground engaging tools enable you to enhance the performance of your wheel loader.



Integrated console and seat suspension gives a greater sense of control and seat-mounted electric control levers reduce fatigue.



Visibility of the job site is excellent thanks to the Aerial Angle® camera system (optional) and new LCD monitor.



Safety is enhanced by the rear obstacle detection and warning system (optional).



The ECO gauge on the monitor indicates how to lower fuel consumption and reduce costs.



Maintenance is quick and easy due to improved access to components and anti-clogging radiators.



Higher engine output at lower engine RPM increases performance.



13

14

12

15

16

17

11

10

4

1

2

3

5

6

8

9

7

Control zone

Enhanced comfort and safety features are at your fingertips in the refined cab of ZW-7 wheel loaders, giving you the power to perform productively, with ease and reduced fatigue.

- 1 **Seat-mounted electric control levers** help to reduce fatigue.
- 2 **Multifunction or finger-type control lever** options to suit your preference.
- 3 **Integrated console and seat suspension** gives a greater sense of control.
- 4 **USB power supply and smartphone holder** helps you stay connected.
- 5 **Armrest-Integrated sub monitor controller** provides fast access to main functions.
- 6 **Ergonomically designed adjustable armrest** so you can work comfortably.
- 7 **User-friendly storage space** keeps your workspace tidy and clutter-free.
- 8 **Heated heavy duty seat** with horizontal suspension.
- 9 **Drinks holder** is easy to detach for cleaning.
- 10 **Anti-slip steering wheel** for effortless operation.
- 11 **3.5" colour liquid crystal display** in the front dashboard is easy to view.
- 12 **Spacious cab** gives you a comfortable workspace.
- 13 **Air conditioning controller** ensures a pleasant working environment.
- 14 **Bluetooth®** for hands-free calls and DAB+ radio for music while you work. Audio is easily controlled.
- 15 **High-resolution 8" monitor** is easy to use and navigate.
- 16 **Panel switch integrated functions** are user-friendly.
- 17 **Electrically adjusted mirrors switch** is easy to use.



Operation is easy with ergonomically designed controls and switches.



All commonly used functions can be selected at a glance using the side panel switch.



Improve your profit

The success of your business depends on the reliability and efficiency of your construction machinery. With Hitachi's latest ZW-7 wheel loaders, you can count on the highest quality, the ultimate in operating comfort and reduced running costs – all of which will have a positive impact on your bottom line.

You can look forward to increasing your profits thanks to the impressive fuel economy and efficient operation of these Stage-V compliant machines. The new ZW180-7 delivers further reductions in fuel consumption and greater efficiency with features such as approach speed control. This allows operators to control the travelling speed on short loading operations, which reduces fuel consumption by 16%.

Another way for your operators to control fuel efficiency – and reduce costs – is by using the all-new ECO gauge. This is clearly visible on the multifunctional colour LCD 3.5" monitor.

Your operators can also work more productively and accurately thanks to the payload checker. This enables them to keep track of load weights in real time on the monitor and find out how much material is in the bucket or truck. The display shows when the bucket or truck is overloaded, so you can adjust the final load to achieve target capacity.

To enhance productivity and save fuel with reduced cycle times, operators benefit from the auto power up function, which automatically increases the RPM to maintain the same travel speed when going uphill.

In addition, you can boost your profits by working on a wide range of applications, with three types of lift arms available: standard, high and parallel.

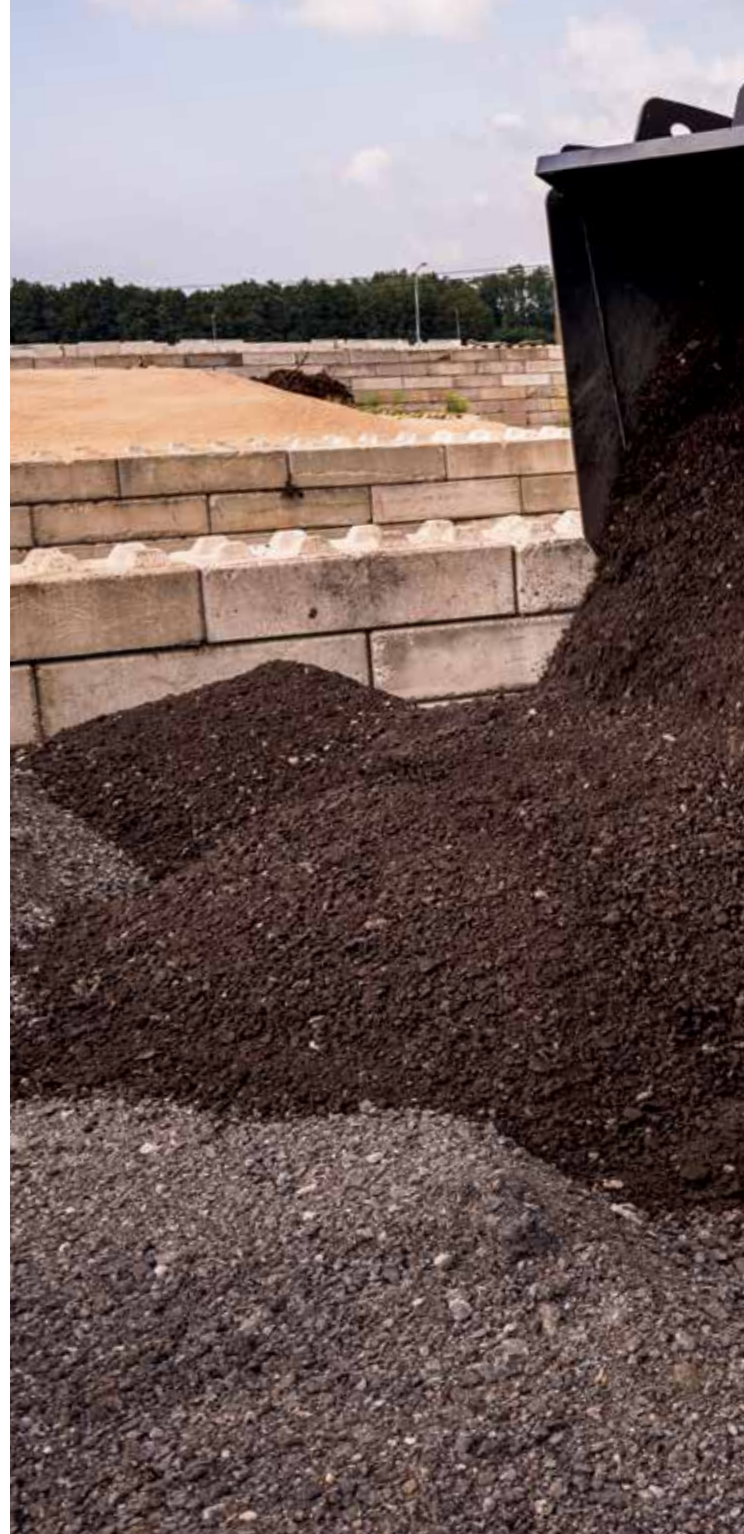

Work more productively and accurately using the payload checker.



The ECO gauge helps to deliver better fuel consumption.



Approach speed control maximises efficiency.



You're in control with a spacious, tidy and enjoyable working environment.



The cab has ample space for your belongings.



The LCD monitor is easy to view with hi-res screen.



In control of your comfort



Feel the difference

Hitachi's redesigned, state-of-the-art ZW-7 cab gives you the perfect working environment. The ultra-spacious ZW180-7 offers you an industry-leading, first-class cab with the ultimate in comfort and quality, as well as some of the lowest noise and vibration levels in the market.

Feel the difference with the synchronised motion of the seat and console, and seat-mounted electric control levers, which have been designed to ensure you feel less tired at the end of the working day.

Easy operation comes with the ergonomic design of the multifunction lever, the anti-slip steering wheel and the 40% larger fully adjustable armrest with integrated controller. You can navigate quickly through the menu on the 8" LCD monitor with the multifunctional controller. The hi-res screen is also easier to view, and the refreshed layout offers a clear display and desirable functionality.

With more storage for your personal belongings, such as your coat, smartphone and drink, you'll feel instantly relaxed and ready for your shift. Practical functions of the control levers, such as the quick power switch and horn, will make your working day effortless.



Ergonomic multifunctional control panel provides easy access.

In control of your environment



Increase your safety

Your ability to work safely is vital, not only for your own wellbeing, but also for the successful completion of any project. To protect yourself and your machine from potential hazards, the new Hitachi ZW-7 wheel loaders give you a superior view of your surroundings, so you can see the job site from all angles.

The visibility you enjoy from the cab includes an exceptional 270-degree bird's-eye view with the Aerial Angle® camera system. You can choose from two image options to view the machine's immediate environment, which enables you to control your own safety – as well as that of those around you.

The rear obstacle detection and warning system also enhances safety on the job site, with real-time speed, machine position status and large detection zone.

To help you to work more confidently and efficiently, even in the most challenging of conditions, ZW-7 wheel loaders are fitted with some impressive new features. From the LED work lights (in two variants: standard 1200lm and high brightness 4200lm) and roller sunshades, you'll have the visibility you need when it matters most.



Electrically adjusted mirrors provide a clear rear view.



Rear obstacle detection system enhances safety on the job site.



Control your safety with the 270-degree view Aerial Angle® camera system.



Choose between different image layouts to suit your working environment.



LED work lights improve visibility in challenging conditions.



Daily inspection reminders make life easier for operators.



Easy maintenance features minimise downtime.



Intelligent fan operation system prevents radiators clogging.



Engine cover enables convenient access for daily inspections.



Hitachi wheel loaders are tested rigorously to ensure high levels of durability.



In control of your assets



Boost your uptime

Completing a project on time and on budget depends on the ability of your construction equipment to perform all day, every day. That's why Hitachi owners have profited from generations of ultra-reliable and durable machinery – and the ZW-7 range is no exception.

The latest Hitachi wheel loaders have been built to last, so that you can remain in complete control of your assets. They have been tested rigorously and continuously at dedicated facilities in Japan with the goal of significantly boosting your uptime.

As a result, several unique durability-enhancing components have been fitted to the latest Stage-V compliant machines. The intelligent fan operation system prevents radiators from clogging by adjusting the periodic intervals of the automatic reversible fan electronically.

Downtime is minimised by the priority given to easy maintenance features, such as the improved cooling package and anti-clogging radiators as standard, which save you time and money.



Manage your machine

Hitachi offers a wide range of after-sales services to help you feel in total control of your fleet and workload. These initiatives give you access to vital data and tools to manage your machine.

Remote monitoring systems Owner's Site and ConSite send operational data daily via GPRS or satellite from your wheel loader to www.globaleservice.com. This includes: ratios of operating hours to enhance efficiency; fuel consumption to manage running costs; and machine location for planning purposes. ConSite summarises the information in a monthly email.

The ConSite Pocket App sends you real-time alerts for issues arising with your machine. You'll receive recommendations on what to do and step-by-step help guides. The app also enables you to see the location of your fleet.



The alerts on the ConSite Pocket App provide real-time information.



A wide range of data on Global e-Service enhances efficiency.



Monitoring the performance of your wheel loader ensures exceptional reliability.



Hitachi offers a wide range of after-sales services for planning maintenance and managing running costs.



Hitachi provides the highest level of technical support.



Minimise downtime with Hitachi Genuine Parts.



HELP extended warranties and service contracts provide optimal performance.



Hitachi Premium Rental enables you to pay as you earn.



In control of your uptime



Protect your investment

If your machine will be working in severe conditions, or you want to minimise repair costs, you can take advantage of a unique extended warranty programme called HELP (Hitachi Extended Life Program) and comprehensive service contracts. These can help to optimise performance, reduce downtime and ensure a higher resale value.

We apply the same technological expertise to our wide range of high-quality parts as we do our machines. As a result, you can minimise unscheduled downtime and ensure maximum availability. The parts range includes Hitachi Genuine Parts, Performance Parts and filters. We also offer robust ground engaging tools and high-quality buckets, which have been manufactured to the same exacting standards.

As your business grows, you may need to extend your fleet to meet the demands of new contracts. Why not try before you buy with the Hitachi Premium Rental programme? This gives you immediate access to ZW-7 wheel loaders and Zaxis-7 excavators for a period of one month to a year.

Along with the reliability, quality and service you would expect from the Hitachi brand, Hitachi Premium Rental offers flexible contracts and fixed costs that make it easier for you to budget.



Customise your machine

Designed to work in perfect harmony with your wheel loader, Hitachi's durable buckets and robust ground engaging tools (GET) will increase your profit by maximising productivity and uptime. Manufactured to the same high standards as all Hitachi construction equipment, they offer unrivalled reliability, exceptional performance and peace of mind that you are getting the most from your Hitachi machine.

The right bucket for the job

You can increase the versatility of your wheel loader by choosing the right bucket for the job. For loading light materials or heavy-duty work, Hitachi buckets can be customised to meet your needs. You have a wide range of options to choose from – including general purpose, rock, high dump and light material buckets – and selectable options such as types of floors and spill guards, side cutter shapes, side wear plates and wear parts are also available. The ISO quick coupling system makes it easy for you to quickly connect Hitachi buckets to your wheel loader.

Enhanced digging power

You can enhance the digging power and productivity of your wheel loader with Hitachi GET. Quick and safe to install and replace, they fit precisely to your attachments and can be tailored to suit the task. Using Hitachi GET can reduce your maintenance costs and downtime, lower fuel consumption and enhance the overall performance of your machine.



Straight side cutter



Convex side cutter

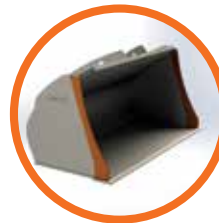

Concave side cutter



Spade edge



Straight edge





Spill guard tube style



Spill guard hood style



Standard spill guard



Spill guard with vision slots



Enlarged spill guard



Teeth

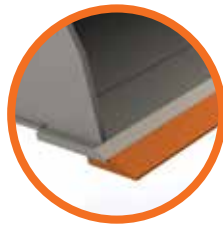

Profiled cutting edge

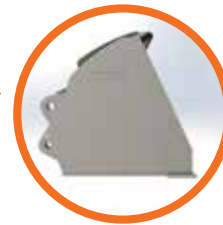

Flat floor



Teeth segments

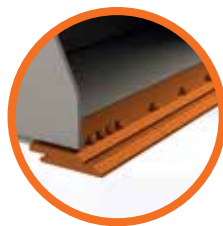

Cutting edge



Round floor



EH dump trucks and EX ultra-large excavators



Special application excavators



Create your vision

In control of your world

With extensive expertise in designing and manufacturing wheel loaders, as well as a 50-year heritage in producing hydraulic excavators and a reputation as the industry's leading mining machine manufacturer, the Hitachi network will give you access to a range of exceptional construction equipment.

Like the new ZW-7 wheel loaders, Hitachi excavators, rigid dump trucks, and special application machines incorporate advanced technology and pioneering expertise. This is inspired by parent company Hitachi Ltd, which was founded on the philosophy to make a positive contribution to society through technology.

In addition to the latest products made at state-of-the-art facilities and built to the highest quality standards, you'll have the support of our experienced engineers and dedicated dealer personnel. You'll also benefit from market-leading services and initiatives, such as Premium Rental and Premium Used, which have been created to enhance your experience as a Hitachi customer.

Whatever vision you wish to create, Hitachi has the product, people, solutions and services you need to make it become a reality – and empower you to take control of your world.



Zaxis medium excavators



Zaxis mini excavators

SPECIFICATIONS

ENGINE

Model	CUMMINS B6.7
Type	4-cycle water-cooled, direct injection
Aspiration	Turbocharger and intercooled
Aftertreatment	DPF and SCR system
No. of cylinders	6
Maximum power	
ECE R120, gross	129 kW (173 hp) at 2 200 min ⁻¹ (rpm)
ISO 9249: 2007, net	125 kW (168 hp) at 2 200 min ⁻¹ (rpm)
Rated power	
ISO 14396: 2002, gross ...	129 kW (173 hp) at 2 200 min ⁻¹ (rpm)
ISO 9249: 2007, net	125 kW (168 hp) at 2 200 min ⁻¹ (rpm)
Maximum torque	
ISO 9249: 2007, net	1 104 Nm at 1 100 min ⁻¹ (rpm)
gross	1 120 Nm at 1 100 min ⁻¹ (rpm)
Bore and stroke	107 mm X 124 mm
Piston displacement	6.69 L
Batteries	2 x 12 V
Air cleaner	Two element dry type with restriction indicator

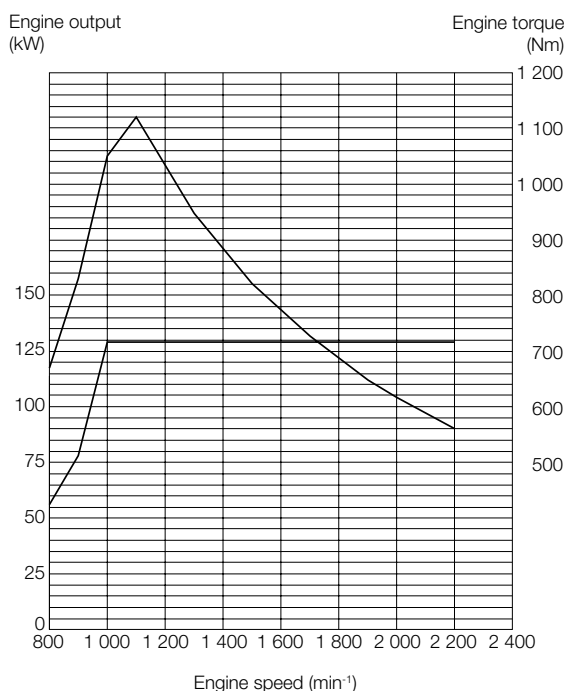

POWER TRAIN

Transmission	Torque converter, countershaft type powershift with computer-controlled automatic shift and manual shift features included.
Torque converter	Three elements, single stage, single phase
Main clutch	Wet hydraulic, multi-disc type
Cooling method	Forced circulation type
Travel speed* Forward / Reverse	
1st	5.9 / 6.2 km/h (6.3 / 6.6 km/h)
2nd	11.5 / 12.1 km/h (12.2 / 12.9 km/h)
3rd	17.5 / 26.5 km/h (18.5 / 28.3 km/h)
4th	25.3 km/h (27 km/h)
5th	39 km/h (39 km/h)
*With 20.5 R25 (L3) tires	
() : Data at Power Mode	

AXLE AND FINAL DRIVE

Drive system	Four-wheel drive system
Front & rear axle	Semi-floating
Front	Fixed to the front frame
Rear	Trunnion support
Reduction and differential gear	Two stage reduction with torque proportional differential
Oscillation angle	Total 20° (+10°, -10°)
Final drives	Heavy-duty planetary, mounted inboard

TIRES

Tire size	20.5R25 (L3)
Optional	Refer to standard & optional equipment list

BRAKES

Service brakes	Inboard mounted fully hydraulic 4 wheel wet disc brakes. Front & rear independent brake circuit
Parking brakes	Spring applied, hydraulically released, dry disc type with external output shaft

STEERING SYSTEM

Type	Articulated frame steering
Steering angle	Each direction 40° ; total 80°
Cylinders	Double-acting piston type
No. x Bore x Stroke	2 x 70 mm x 442 mm

HYDRAULIC SYSTEM

Arm and bucket are controlled by multifunction lever		
Arm controls	Four position valve; Raise, hold, lower, float	
Bucket controls with automatic bucket return-to-dig control	Three position valve; Roll back, hold, dump	
Main pump (Serve as steering pump)	Variable Displacement Axial Plunger Pump	
Maximum flow	224 L/min at 2 200 min ⁻¹ (rpm)	
Maximum pressure ..	27.4 MPa	
Fan pump	Fixed Displacement Gear Pump	
Maximum flow	54.8 L/min at 2 200 min ⁻¹ (rpm)	
Maximum pressure ..	18.2 MPa	
ZW180-7 Hydraulic cylinders		
Type	Double acting type	
No. x Bore x Stroke ...	Arm : 2 x 125 mm x 765 mm Bucket : 1 x 150 mm x 495 mm	
Filters	Full-flow 15 micron return filter in reservoir	
ZW180PL-7 Hydraulic cylinders		
Type	Double acting type	
No. x Bore x Stroke ...	Arm : 2 x 125 mm x 765 mm Bucket : 2 x 110 mm x 955 mm	
Filters	Full-flow 15 micron return filter in reservoir	
Hydraulic cycle times	ZW180-7	ZW180PL-7
Lift arm raise	5.3 s	5.3 s
Lift arm lower	3.7 s	3.7 s
Bucket dump	1.1 s	2.3 s
Total	10.1 s	11.3 s

*Data at Power Mode

ENVIRONMENT

Engine Emissions

EU Stage V

Sound level

External sound level according to ISO 6395: 2008 and EU Directive 2000/14/EC	104 LwA dB(A)
Sound level in cabin according to ISO 6396: 2008	67 LpA dB(A)

Air Conditioning System

The air conditioning system contains fluorinated greenhouse gases.
Refrigerant type: HFC-134a, GWP: 1430, Amount: 0.75±0.05kg, CO2e: 1.07±0.07ton.

SERVICE REFILL CAPACITIES

Fuel tank	230 L
Engine coolant	25 L
Engine oil	25 L
Torque convertor & transmission	30 L
Front axle differential & wheel hubs	31 L
Rear axle differential & wheel hubs	34 L
Hydraulic oil tank	100 L
DEF/AdBlue® tank	25 L

DIMENSIONS & SPECIFICATIONS ZW180-7

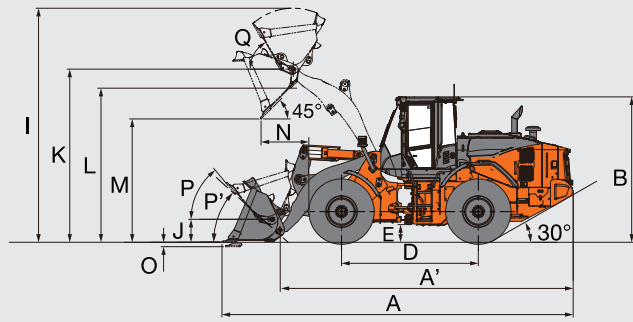
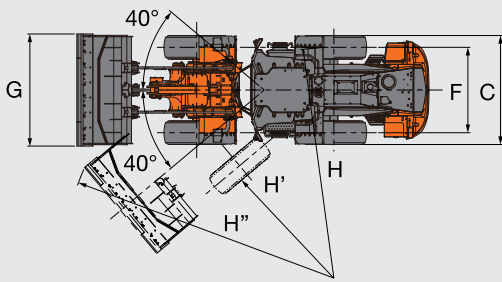

Bucket type		Standard arm					High-lift arm		
		General purpose				High volume	General purpose		
		Weld-on teeth	Bolt-on cutting edge	Weld-on teeth	Bolt-on cutting edge	Bolt-on cutting edge	Bolt-on cutting edge		
Bucket capacity	ISO 7546: 1983 Heaped	m ³	2.6	2.6	2.8	2.8	5.2	2.6	2.8
	ISO 7546: 1983 Struck	m ³	2.2	2.2	2.4	2.4	4.4	2.2	2.4
A Overall length		mm	8 085	7 975	8 135	8 025	8 430	8 470	8 520
A' Overall length (Without Bucket)		mm	6 725	6 725	6 725	6 725	6 725	7 225	7 225
B Overall height	up to cab top	mm	3 310	3 310	3 310	3 310	3 310	3 310	3 310
C Width over tires	outside tire	mm	2 505	2 505	2 505	2 505	2 505	2 505	2 505
D Wheel base		mm	3 100	3 100	3 100	3 100	3 100	3 100	3 100
E Ground clearance	Minimum	mm	400	400	400	400	400	400	400
F Tread		mm	1 930	1 930	1 930	1 930	1 930	1 930	1 930
G Bucket width		mm	2 535	2 535	2 535	2 535	2 950	2 535	2 535
H Turning radius (Centerline of outside tire)		mm	5 235	5 235	5 235	5 235	5 235	5 235	5 235
H' Turning radius to inside of tires		mm	2 995	2 995	2 995	2 995	2 995	2 995	2 995
H'' Loader clearance radius, bucket in carry position		mm	6 145	6 115	6 160	6 130	6 420	6 330	6 345
I Overall operating height	bucket full raise	mm	5 280	5 280	5 345	5 345	5 840	5 685	5 750
J Carry height of bucket pin	at carry position	mm	400	400	400	400	400	400	400
K Height to bucket hinge pin, fully raised		mm	3 925	3 925	3 925	3 925	3 925	4 335	4 335
L Lift arm clearance at max. lift		mm	3 670	3 645	3 670	3 645	3 650	4 055	4 055
M Dumping clearance 45 deg, full height		mm	2 710	2 785	2 675	2 750	2 465	3 190	3 155
N Reach 45 deg dump, full height		mm	1 205	1 095	1 240	1 130	1 415	1 245	1 280
O Digging depth (Horizontal digging angle)		mm	70	95	70	95	95	170	170
P Max. roll back at carry position		deg	47	47	47	47	47	47	47
P' Max. roll back at ground level		deg	43	44	43	44	44	45	45
Q Roll back angle at full height		deg	60	60	60	60	60	53	53
Static tipping load ISO 14397-1:	Straight	kg	12 570	12 440	12 570	12 450	12 040	9 790	9 780
2007(Section 1-5) *	Full turn	kg	10 880	10 750	10 870	10 750	10 330	8 410	8 400
Breakout force		kN	128	117	122	112	81	107	103
		kgf	13 010	11 920	12 430	11 410	8 300	10 940	10 470
Operating weight * (With ROPS / FOPS Cab)		kg	14 950	15 040	14 960	15 080	15 470	15 240	15 270

Note
 : Static tipping load and operating weight marked with include 20.5R25 (L3) tires (No ballast) with lubricants, full fuel tank and operator.
 Machine stability and operating weight depend on counterweight, tire size and other attachments.

WEIGHT CHANGE

Option item	Operating weight (kg)	Tipping load (kg)		Overall width (mm) (outside tire)	Overall height (mm)	Overall length (mm)
		Straight	Full turn			
Tire	20.5R25(L3) XHA2	±0	±0	±0	±0	±0
	20.5R25(L5) XLDD2A	+460	+370	+320	+15	+25
	20.5R25(L5) XMINED2 PRO	+620	+490	+430	+10	+35
	20.5R25(L2) XSNOPLUS	+70	+70	+60	+5	-10
	20.5R25(L3) VJT	+10	+30	+30	-5	-5
	20.5R25(L3) TL-3A+	+150	+140	+120	+10	-5
Belly guard	+165	+120	+110	±0	±0	±0

BUCKET SELECTION GUIDE

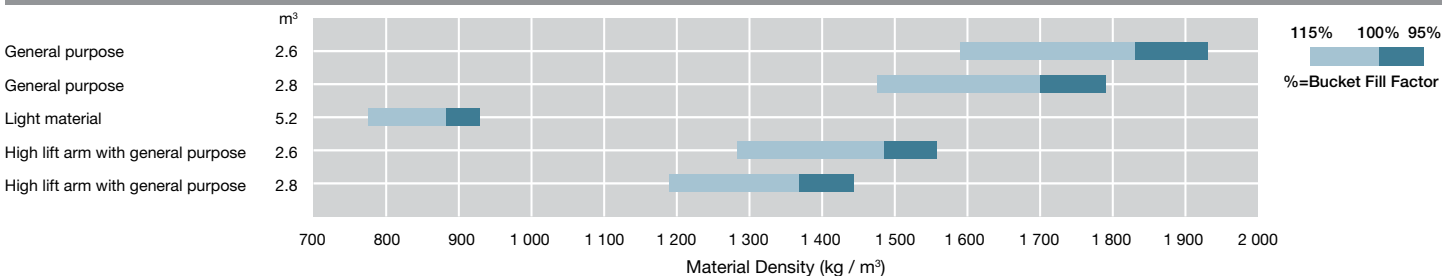

SPECIFICATIONS

DIMENSIONS & SPECIFICATIONS ZW180PL-7

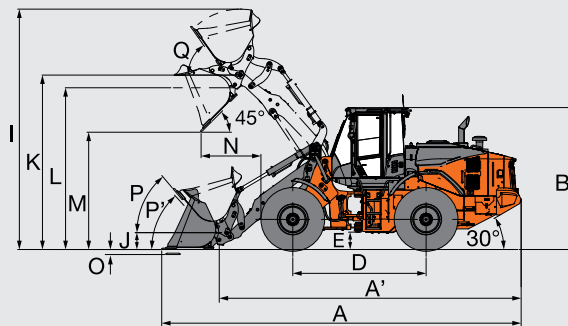
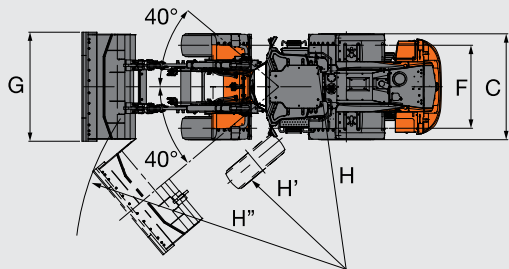

		General purpose						
		Bolt-on cutting edge			Weld-on teeth			
Bucket capacity	ISO 7546: 1983 Heaped	m ³	2.6	2.8	3.1	2.5	2.7	3.0
	ISO 7546: 1983 Struck	m ³	2.3	2.4	2.7	2.2	2.3	2.6
A Overall length		mm	8 330	8 380	8 480	8 450	8 500	8 600
A' Overall length (Without Bucket)		mm	7 020	7 020	7 020	7 020	7 020	7 020
B Overall Height	up to cab top	mm	3 310	3 310	3 310	3 310	3 310	3 310
C Width over tires	outside tire	mm	2 505	2 505	2 505	2 505	2 505	2 505
D Wheel base		mm	3 100	3 100	3 100	3 100	3 100	3 100
E Ground clearance	Minimum	mm	400	400	400	400	400	400
F Tread		mm	1 930	1 930	1 930	1 930	1 930	1 930
G Bucket width		mm	2 535	2 535	2 535	2 535	2 535	2 535
H Turning radius (Centerline of outside tire)		mm	5 235	5 235	5 235	5 235	5 235	5 235
H' Turning radius to inside of tires		mm	2 995	2 995	2 995	2 995	2 995	2 995
H'' Loader clearance radius, bucket in carry position		mm	6 190	6 205	6 230	6 225	6 240	6 270
I Overall operating height	bucket full raise	mm	5 590	5 650	5 720	5 590	5 650	5 720
J Carry height of bucket pin	at carry position	mm	400	400	400	400	400	400
K Height to bucket hinge pin, fully raised		mm	4 050	4 050	4 050	4 050	4 050	4 050
L Lift arm clearance at max. lift		mm	3 760	3 760	3 760	3 760	3 760	3 760
M Dumping clearance 45 deg, full height		mm	2 720	2 690	2 620	2 650	2 610	2 540
N Reach 45 deg dump, full height		mm	1 390	1 420	1 490	1 510	1 540	1 610
O Digging depth (Horizontal digging angle)		mm	110	110	110	80	80	80
P Max. roll back at carry position		deg	50	50	50	50	50	50
P' Max. roll back at ground level		deg	48	48	48	48	48	48
Q Roll back angle at full height		deg	55	55	55	55	55	55
Bucket weight		kg	1 290	1 330	1 390	1 190	1 230	1 290
Static tipping load ISO 14397-1: 2007(Section 1-5) *	Straight	kg	10 770	10 730	10 670	10 930	10 840	10 780
	Full turn	kg	9 260	9 230	9 180	9 400	9 320	9 270
Breakout force		kN	112	108	101	120	116	108
		kgf	11 400	11 000	10 300	12 200	11 800	11 000
Operating weight * (With ROPS / FOPS Cab)		kg	15 610	15 650	15 710	15 510	15 550	15 610

WITH FORK ATTACHMENT

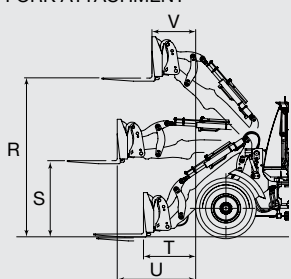

Attachment type		Fork
R	Max. stacking height	mm
S	Height of fork at maximum reach	mm
T	Reach at ground level	mm
U	Max. reach	mm
V	Reach at max. stacking height	mm
Static tipping load	Straight	kgf
	Full 40 degree turn	kgf
Max. payload per EN 474-3, 80 %		kg
Max. payload per EN 474-3, 60 %		kg
Fork tine length		mm
Operating weight *		kg

Note: *: Static tipping load and operating weight marked with* include 20.5R25 (L3) tires (No ballast) with lubricants, full fuel tank and operator. Machine stability and operating weight depend on counterweight, tire size and other attachments.

WEIGHT CHANGE

Option item	Operating weight (kg)	Tipping load (kg)		Overall width (mm) (outside tire)	Overall height (mm)	Overall length (mm)
		Straight	Full turn			
Tire	20.5R25(L3) XHA2	±0	±0	±0	±0	±0
	20.5R25(L5) XLDD2A	+460	+310	+260	+15	+25
	20.5R25(L5) XMINED2 PRO	+620	+410	+350	+10	+35
	20.5R25(L2) XSNOPPLUS	+70	+60	+50	+5	-10
	20.5R25(L5) VJT	+10	+20	+20	-5	-5
	20.5R25(L5) TL-3A+	+150	+110	+100	+10	-5
Belly guard	+165	+120	+110	±0	±0	±0

BUCKET SELECTION GUIDE

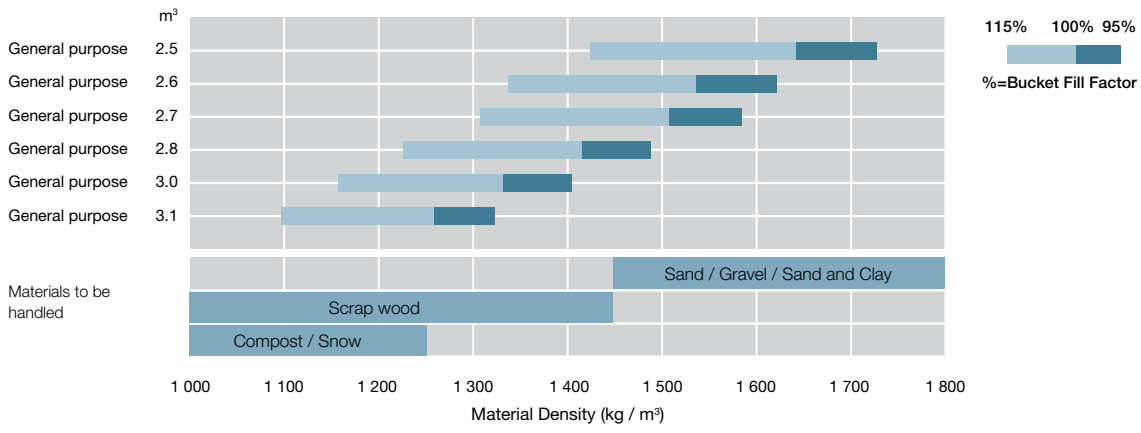

EQUIPMENT

● Standard equipment

○ Optional equipment

ENGINE	ZW180-7	ZW180PL-7
Aftertreatment device	●	●
Aftertreatment manual regeneration inhibit switch	●	●
Aftertreatment manual regeneration switch	●	●
Air filter double elements	●	●
Air intake		
Pre-cleaner (Sy-Klone type)	●	●
Pre-cleaner (Turbo II)	○	○
Anti-clogging radiator (Wide fin pitch)	●	●
Automatic reversible cooling fan with heat sensing	●	●
Cartridge-type engine oil filter	●	●
Cartridge-type fuel main filter	●	●
Cartridge-type fuel pre-filter (with water separator function)	●	●
Coolant reserver sight gauge	●	●
DEF/AdBlue® tank	●	●
DEF/AdBlue® tank with magnet adapter	●	●
Engine auto shut-down control system	●	●
Engine oil remote drain	●	●
Fan guard	●	●

BRAKE SYSTEM		
Front & rear independent brake circuit	●	●
Inboard mounted fully hydraulic 4 wheel wet disc	●	●
Spring applied/Hydraulic-released parking brake	●	●

HYDRAULIC SYSTEM		
Bucket auto leveler (Automatic return to dig control)	●	●
Control lever lock switch	●	●
Dual lift arm auto leveler and kickout system	●	●
Electric control lever		
for 3 spools control valve		
MF lever & Proportional switch for 3rd function	●	●
2 levers & AUX lever for 3rd function - Inside layout pattern (3rd - bucket - liftarm)	○	○
for 4 spools control valve		
MF lever & 2 Proportional switch for 3rd & 4th function	○	–
2 levers & AUX lever for 3rd function & Proportional switch for 4th function - Inside layout pattern (4th - 3rd - bucket - liftarm)	○	–
Hydraulic filters	●	●
Lift arm float system	●	●
Reservoir sight gauge	●	●
Ride control system (OFF-AUTO type)	●	●
Quick coupler piping and switch	○	●
Work mode selector	●	●

CAB	ZW180-7	ZW180PL-7
Adjustable steering column with POP-UP	●	●
Auto control air conditioner		
with double intake filters	●	●
Pre-cleaner for air conditioner	○	○
Bluetooth® integrated DAB+radio, hands-free calling	●	●
Camera & monitor		
Rear view camera & monitor	●	●
AERIAL ANGLE® (Side and rear view camera)	○	○
Coat hook	●	●
Evacuation hammer	●	●
Front/Rear defroster	●	●
Glove compartment	●	●
LED room light	●	●
Payload checker with tip-off function	●	–
Rear obstacle detection system	○	○
Rear view mirrors		
Inside (1)	●	●
Outside (Heated, 2) electrical adjustment with proximity	●	●
Retractable seat belt, 50 mm	●	●
ROPS (ISO 3471:2008), FOPS (ISO 3449:2008 LEVEL II): multi-plane isolation mounted for noise, vibration reduction	●	●
Rubber floor mat	●	●
Seat		
Heavy Duty air suspension seat equipped with horizontal suspension, headrest and heater: fabric, high back, adjustable for damper, inclination of the seat, seat depth, weight-height, fore-aft position, reclining angle, armrest angle, headrest height and angle, lumbar support	●	●
Seat belt reminder	●	●
Steering system		
Wheel steering	●	●
Storage		
Cup holder	●	●
Document holder	●	●
Hot & cool box	●	●
Seatback pocket	●	●
Smartphone and Tablet device holder	●	●
Sun shade film on front windshield	○	○
Sunscreen roller type	●	●
Textured steering wheel with spinner knob	●	●
Tinted safety glass		
Front windshield: laminated	●	●
Others: tempered	●	●
USB power supply	●	●
Windshield washer front and rear	●	●
Windshield wipers front and rear	●	●
8 inch sub monitor	●	●
2 speakers	●	●

MONITORING SYSTEM	ZW180-7	ZW180PL-7
Gauge: coolant temperature, fuel level, transmission oil temperature	●	●
Indicator lights : clearance lights, control lever lock, fuel level, high beam, parking brake, preheat, turn signals, work lights, fan reverse indicator, seat belt indicator	●	●
Indicator on multifunction monitor: F-N-R shift position, gear shift position, clock, DEF alarm indicator, DEF level gauge, ECO indicator, forward/reverse selector switch indicator, hold display, hour meter, odometer, battery volt, speedometer, tachometer, transmission auto-shifting indicator, Warning lights: air filter restriction, brake oil low pressure, communication system error, discharge warning, engine oil low pressure, engine warning, hydraulic oil level, low steering oil pressure, overheat, transmission warning	●	●
Indicator on sub monitor : payload checker (excluding PL), dual auto-leveler indicator rear obstacle detection and warning system (optional)	●	●
38 languages selection	●	●

ELECTRICAL SYSTEM	ZW180-7	ZW180PL-7
Alternator (95A)	●	●
Backup alarm	●	●
Battery disconnect switch	●	●
Large capacity batteries	●	●
Power outlet 12 V and 24 V	●	●

LIGHTS	ZW180-7	ZW180PL-7
Clearance lights	●	●
LED brake & tail lights	●	●
LED headlights	●	●
Rotating lamp	○	○
Turn signals with hazard switch	●	●
Work lights		
2 front on cab & 2 rear LED working lights	●	●
2 front on cab & 2 rear LED working lights (High brightness)	○	○
4 front, 2 rear on cab & 2 rear LED working lights	○	○
4 front, 2 rear on cab & 2 rear LED working lights (High brightness)	○	○

POWER TRAIN	ZW180-7	ZW180PL-7
Approach speed control	●	●
Automatic transmission with load sensing system	●	●
Clutch cut position switch	●	●
Differential		
LSD (Limited Slip Differential, front and rear)	○	○
TPD (Torque Proportioning Differential, front and rear)	●	●
Driving speed limiter (20 km/h)	○	○
DSS (Down Shift Switch)	●	●
Forward/Reverse lever	●	●
Forward/Reverse selector switch	●	●
Maximum gear limited switch	●	●
Power mode switch	●	●
Quick power switch	●	●
Travel mode selector (Auto1-Auto2)	●	●

TIRES	ZW180-7	ZW180PL-7
20.5R25 (L3) XHA2	●	●
20.5R25 (L5) XLDD2A	○	○
20.5R25 (L5) XMINED2 PRO	○	○
20.5R25 (L2) XSNOPLUS	○	○
20.5R25 (L3) VJT	○	○
20.5R25 (L3) TL-3A+	○	○

MISCELLANEOUS	ZW180-7	ZW180PL-7
Articulation lock bar	●	●
Auto lubrication system	○	–
Belly guard (Bolt on type) (front / rear)	○	○
Bucket cylinder guard	○	○
Cab top rail		
Front rail on the cab top	●	●
Rear rail on the cab top	●	●
Counterweight, built-in	●	●
Cutting edge protection	○	○
Drawbar with locking pin	●	●
Emergency steering	●	●
Fenders		
for 20.5 R25 (Front & full covered rear fenders with mud flaps)	●	●
Global e-Service	●	●
Lift arm		
Standard lift arm	●	–
High lift arm	○	–
Parallel lift arm	–	●
Lift & tie down hooks	●	●
On board information controller	●	●
Pilfer proof		
Battery cover with locking bracket	●	●
Lockable engine cover	●	●
Lockable fuel refilling cap	●	●
Quick coupler	–	●
Radiator dust protection screen	○	○
Rear licence plate bracket	○	○
Road homologation		
German road homologation kit: rear license plate bracket, reflective sticker, wheel blocks	○	○
Italian road homologation kit: cab lights, bucket cutting edge protection, link stopper, rear license plate bracket, reflective sticker, rotating lamp	○	○
Spanish road homologation kit: rear license plate bracket, rotating lamp	○	○
Standard tool kit	●	●
Tool box	●	●
Wheel blocks	○	○

Prior to operating this machine, including satellite communication system, in a country other than a country of its intended use, it may be necessary to make modifications to it so that it complies with the local regulatory standards (including safety standards) and legal requirements of that particular country. Please do not export or operate this machine outside the country of its intended use until such compliance has been confirmed. Please contact your Hitachi dealer in case of questions about compliance.

These specifications are subject to change without notice. Illustrations and photos show the standard models, and may or may not include optional equipment, accessories, and all standard equipment with some differences in color and features. Before use, read and understand the Operator's Manual for proper operation.

